



SOLO Owner's Manual

**PRO
LAZER**

**LAZER
LAZER LIGHTWEIGHT MAG**

CHIPPERMAG



⚠ ATTENTION: PRIOR TO FIRST USE ⚠

It is recommended that everyone who uses this product should read the StrikeMaster owner's manual.

This engine is equipped with a decompression valve for easier starting. Press the button in before every start to reduce cylinder pressure.

For best performance idle engine for 1-2 minutes before you start drilling.

STRIKEMASTER® Ice Augers

Ice Fishing has become one of the fastest growing and most popular winter sports, allowing the ardent angler the opportunity to enjoy his or her favorite outdoor activity.

When you purchased a StrikeMaster® power ice auger, you selected a product that has gained a reputation as the quality leader since 1946. There is no doubt that this year's model is the finest ever produced by StrikeMaster Corporation.

Your new StrikeMaster ice auger has all of the most wanted features in a power ice auger, to assure many years of enjoyable ice fishing. Some of these features such as workmanship, engineering excellence, and dependability have long been standards at StrikeMaster. Your new power ice auger boasts many new features while retaining the best features developed in previous years to enhance your ice fishing experience and add to your satisfaction in selecting StrikeMaster.

We know that you are anxious to go fishing and use your new power ice auger, but before you go fishing, it is important and to your advantage to spend a few minutes getting acquainted with your new StrikeMaster power ice auger. There is no better way to acquaint yourself with the product than to read the Owners Manual and operating instructions. A few minutes spent studying this manual before your first ice fishing outing will be time well spent.

Record the engine serial number, engine type and date purchased in the space below. Also, please return the enclosed WARRANTY CARD or submit your information at www.strikemaster.com to validate your limited warranty.

Model: Lazer Pro, Lazer Mag & Chipper Mag

Serial Number _____ Engine Type _____

Spec # _____ CC _____ DOM _____

Date Purchased ____/____/____

ENGINE TYPE	SPEC #	DOM	SERIAL NUMBER
Typ: 154			
S-Nr: 2000694-0414-201041		2014	
EMMISSION CONTROL INFORMATION			
SOLO INCORPORATED D50XS005455A			
EMMISSION COMPLIANCE PERIOD = 300HRS			
54.2cc		04/2014	
EXHAUST EMISSION CONTROL			
Exhaust Manifold/Muffler			
THIS ENGINE MEETS US EPA EXH/EVP			
REGS FOR MODEL YEAR 2014			
Refer to operator's manual for maintenance, lubrication			
requirements, specifications and adjustments			
e1*97/68SH3-IA*2002/88* 0269*01			

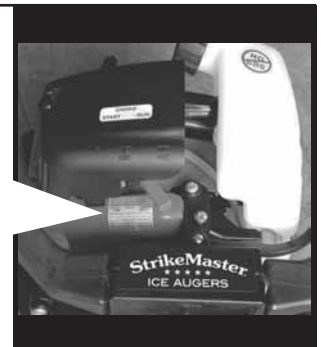

⚠ ATTENTION ⚠

⚠ THIS SYMBOL POINTS OUT IMPORTANT SAFETY INSTRUCTIONS WHICH IF NOT FOLLOWED COULD ENDANGER THE PERSONAL SAFETY AND/OR PROPERTY OF YOURSELF AND OTHERS. READ AND FOLLOW ALL INSTRUCTIONS IN THIS MANUAL AND ANY PROVIDED WITH OR ON THE EQUIPMENT ON WHICH THIS ENGINE IS USED BEFORE ATTEMPTING TO OPERATE YOUR STRIKEMASTER POWER ICE AUGER.

TABLE OF CONTENTS

Important Safeguards/Component & Control Locations.....	3
Assembly Instructions.....	4
Operation Instructions.....	4
Fueling: Oil/Fuel Instructions	5
Engine Start Preparations	6
Engine Start Instructions	6
Stop Engine	6
Maintenance	7
Storage	7
SOLO® Engines Limited Warranty	9-10
STRIKEMASTER Limited Warranty	(back cover)

Rapala

Otter
Outdoor
TOUGHER. | TRONGER. | SMARTER.

50105

StrikeMaster
ICE AUGERS



⚠ IMPORTANT SAFEGUARDS ⚠

It is recommended that everyone who uses this product should read this StrikeMaster Owner's Manual before operating.

1. **DO NOT** use this product for any purpose other than cutting ice fishing holes. Ice augers are precision cutting tools built for the ice fisherman, and must be properly maintained and handled with caution during both cutting and transporting. When not in use, always store with blade guard attached.
2. **DO NOT** use attachments other than those available from the manufacturer.
3. **DO NOT** alter this product in any manner; doing so is dangerous and voids all warranties.
4. **DO NOT** allow children or adults weighing under 100 lbs. to operate this equipment.
5. **DO NOT** operate under the influence of drugs or alcohol.
6. **DO NOT** allow your body, loose clothing, drawstrings, scarves, hats or other materials to come in contact with the Powerhead, Starter Assembly or Auger (Drill) unit at any time.
7. **DO NOT** operate if, upon pulling the starter rope or after drilling holes, the auger (drill) rotates or if the rope pulls hard. Have the unit checked by a qualified mechanic.
8. **DO NOT** allow the engine to run or operate while moving or transporting to another location.
9. **DO NOT** continue to use this product in the event of mechanical or electrical failure.
10. This product produces considerable cutting force that is felt by the operator. Make sure your feet are firmly planted and that the handles are held firmly while operating this product.
11. Always check the operation of the throttle system to ensure the carburetor control is completely returning to the idle position when the throttle lever is released.
12. **Check cutting blades and auger shaft screws before and after each use to make sure they are tight.**
13. During operation, the auger unit could possibly stop. Be prepared at all times to release the throttle lever.
14. The cutting blades on the ice auger are razor sharp. Use extreme care when handling.

⚠ PACKAGING & DISPOSAL ⚠

Please keep the original packaging in order to protect the equipment against damage in case you ever need to ship or transport the auger. If the packaging materials are no longer required then they must be disposed of properly in accordance with applicable local regulations. Cardboard packaging materials are raw materials which can be recycled or reused. At the end of the equipment's service life, please make sure that you dispose of it properly, in accordance with the official directives and regulations that apply in your area.

COMPONENT & CONTROL LOCATIONS

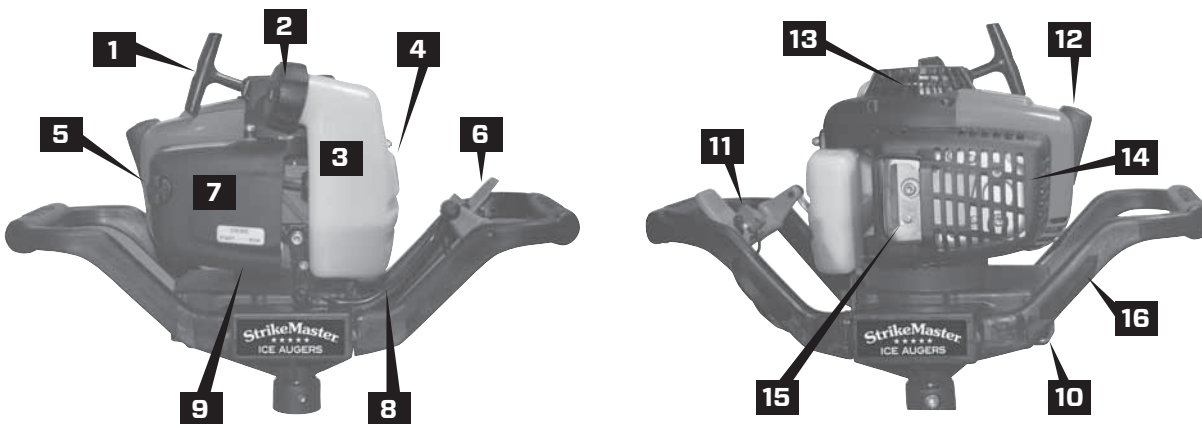

- | | | | |
|----------------------------|------------------------|-----------------------|----------------------------|
| 1. Recoil (Starter) Handle | 5. Decompression Valve | 9. Choke Lever | 13. Recoil |
| 2. Fuel Cap | 6. Throttle Lever | 10. Transmission | 14. Muffler/Cylinder Guard |
| 3. Fuel Tank | 7. Air Filter Cover | 11. Start/Stop Switch | 15. Muffler |
| 4. Fuel (FULL) Level | 8. Throttle Arm | 12. Spark Plug Cover | 16. Handle Assembly |

⚠ ASSEMBLY ⚠

- 1** Carefully remove blade guard and make sure blade bolts are tight.
(Use 8mm closed end wrench for Lazer blades)
(Use two 10mm closed end wrenches for chipper blades)



- 2** Remove Metric Allen wrench attached to the neck of the auger and unscrew the collar bolt from auger.

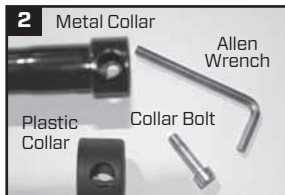

- 2a** The large and small holes from each component must line up before installing the collar bolt.



Push down and twist to line up holes.

- 3** It is recommended to grease inside metal collar and transmission output shaft on the powerhead. Standard automotive wheel bearing grease is suggested. Insert drive shaft into auger and install collar bolt.



- 3a** Collar bolt inserts into the large hole, passing through the drive shaft and threads into small hole of metal collar. Tighten bolt. Some wiggle is normal between the power head and auger. Tighten often.



- 4** After assembly is complete, you can conveniently store your allen wrench on the underside of the throttle pedal.



- ⚠ It is recommended that the blade and collar bolts be checked and torqued firmly before and after every use.

⚠ DECOMPRESSION VALVE ⚠

This engine is equipped with a decompression valve for easier starting. Press the valve in before every pull to reduce cylinder pressure. If engine fails to stop simply press decompression valve in.



⚠ OPERATION ⚠

1. Start engine as explained on page 6 of this manual. For best cutting performance, run engine at idle for 1-2 minutes before drilling.
2. Hold the unit in a vertical position with your right hand pushing downward to open throttle, and your left hand firmly holding the opposite handle.
3. This product produces considerable cutting force that is felt by the operator. Make sure your feet are firmly planted and that the handles are held firmly while operating this product.
4. Push the throttle lever downward to increase the engine speed. As the engine speed increases the centrifugal clutch will engage and the auger will begin to rotate.
5. During the operation of cutting, the auger could possibly stop if it comes in contact with a foreign object or if it binds in the hole. Be prepared at all times to release the throttle lever to avoid rotation of the handle assembly.
6. Stop engine if you notice a difference in the operating characteristics of this machine.
7. Always stop the engine before any contact with the auger, even when clearing ice blockage.
8. Never touch the muffler due to a risk of burns!
9. The cutting blades on this auger are razor sharp. Use extreme care when handling and installing blades and blade guards.
10. After using this machine, **STOP** the engine by allowing the engine to return to idle and moving the switch to the OFF position. If engine fails to stop, press the decompression valve in to shut off the engine. If the ignition switch has failed, **DO NOT OPERATE** until the ignition switch has been repaired by an qualified mechanic.
11. Always check to make sure the throttle system is moving freely and returning to idle.
12. Turn off this machine when traveling from fishing site to fishing site.
13. Always store auger with blade guard attached.

FUELING: OIL/FUEL INSTRUCTIONS

Your new 2-stroke Solo auger engine does not come filled with a fuel/oil mix. You will need to add a fuel/oil mix prior to your first use. (See below) Fuel is highly flammable. Keep away from open flames and never spill fuel. Do not smoke at the operating site or near the refueling site.

- Stop the engine prior to refueling.
- Let the engine cool down before refueling.
- Open fuel cap slowly to allow any excess pressure in the tank to be reduced without the risk of fuel spraying out.
- Fuel may contain substances similar to solvents. Wear protective gloves during filling.
- Avoid breathing in fuel vapor.
- Immediately clean any spilled fuel on the machine.
- Firmly tighten fuel cap.
- Check for fuel leaks. Do not start the machine or work with the machine if there is a fuel leak.
- Store fuel and oil in an approved and correctly labeled container.

1. The Solo engine has a non-vented gas cap. Air is supplied to the tank using an external venting system. (Fig 1)
2. You will notice the air line located under the fuel cap. The airline needs to maintain this position in order to allow air to the tank. (Fig 2)
3. To prevent excessive fuel from collecting in the air line we have the following suggestions. DO NOT OVER FILL THE GAS TANK.
4. When the auger is not in use, lay it down as shown. (Fig 3) Position #1 is the best option followed by position #2. (Fig 4) This will keep the air line out of the fuel.

FUEL INFORMATION

- Use unleaded regular, unleaded premium or non-oxygenated fuel. Do not use fuel with less than an octane rating of 87. For peak performance use a 90-93 octane rated unleaded premium fuel.
- Do not use leaded fuel or E85.
- FUEL MUST BE FRESH AND CLEAN. NEVER use fuel left over from last season or fuel that has been stored more than 30 days. Do not use summer blend fuel; only use winter blend fuel which is available after November 1st.
- Unsuitable fuel or deviations in mixing ratio may lead to serious engine damage which is not covered under warranty.

2-CYCLE OIL/FUEL MIX

To operate your engine you will need to use a clean, high-quality, 2-cycle oil. We recommend StrikeMaster 2-cycle Low Smoke Engine Oil mixed with fuel at a ratio of 40:1 (3.2 fl. oz. to 1 gallon of gasoline). **DO NOT** use a fuel/oil mixture leaner than 50:1 (2.6 fl. oz. to 1 gallon of gasoline).

- All 2-stroke engines will have some oil residue that slowly comes from the muffler area; this is normal.
- Full Synthetic 2-stroke oil may be used as long as fuel/oil mixture ratio does not exceed 50:1 (2.6 fluid oz. oil to 1 gal. gas).



AIR VENT PART #2700430

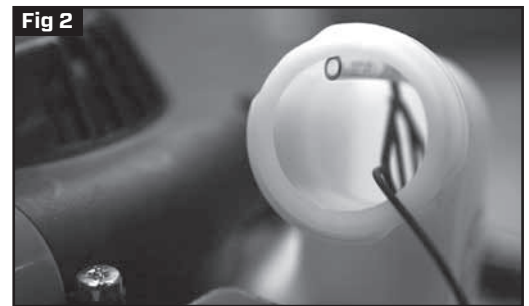

AIR LINE PART #64474



POSITION #1

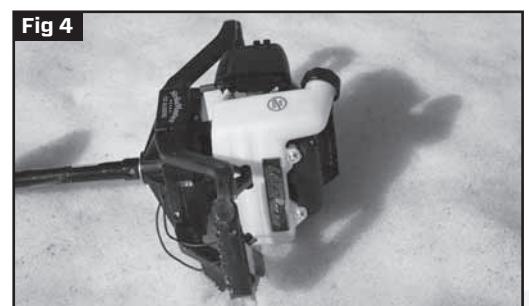

POSITION #2

⚠ ENGINE START PREPARATIONS ⚠

- Check the complete machine for operational safety.
- The stop switch should function properly.
- The throttle must have freedom of movement and return to the idle position on its own accord.
- The auger blades and collar bolt must be tightly secured and in excellent working order.
- Ensure the spark plug cap and ignition cable are connected firmly.
- Remove fuel cap to ensure that the clear vent tube is up in the filler tank neck and not pushed down or submersed in fuel.



⚠ ENGINE START INSTRUCTIONS ⚠

1. Turn the ON/OFF switch to **ON**. Make sure to read the switch correctly. (Fig 1)
2. Press the primer bulb (Fig 2) 5 to 8 times. You want to see fuel returning in the fuel line.
3. Slide the choke lever to **START** position. (Fig 3)
4. Press the decompression valve (Fig 4). Pull the recoil handle in short quick pulls until the engine fires. (audible sound)
NOTE: you will need to press the decompression valve in after every pull of the recoil rope.

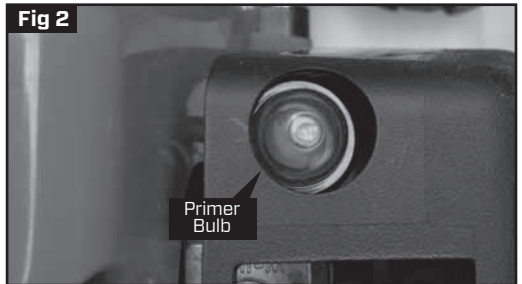

Once the motor has fired, slide the choke lever to **RUN** (no choke), and continue. Repeat step 4 until engine starts. If engine fails to start, repeat steps 1-4.

If the engine fails to start after several attempts, check that all adjustments described above have been done correctly. Be sure the on/off switch is **NOT** in the off position and start once again. If the engine still fails to start, contact your local Solo authorized repair center located on our website.

STARTING TIPS: As you know, very cold temperatures make all engines a little harder to start. Whenever possible, keeping your machine in a warm environment will ALWAYS make it easier to start.

www.strikemaster.com

⚠ STOP ENGINE ⚠

After completing the cutting of an ice fishing hole, **STOP** the engine by allowing the engine to return to idle and moving the ON/OFF switch to the **OFF** position. If engine fails to stop simply press decompression valve in or slide choke lever to start (full choke). Do not operate until switch has been repaired by a qualified mechanic.

⚠ MAINTENANCE ⚠

AIR FILTER

Contaminated air filters cause a reduction in engine performance and increase fuel consumption with more pollutants in the exhaust gas. Engines are less likely to start readily with a contaminated air filter. Carry out the following maintenance jobs regularly:

Before opening the air filter, close the choke to prevent dirt from entering the carburetor.

- Turn the wing screw at the air filter cover counter-clockwise.
- Flip the top of the air filter cover forward and remove.
- Remove the fabric air filter.
- Clean the area around the filter.

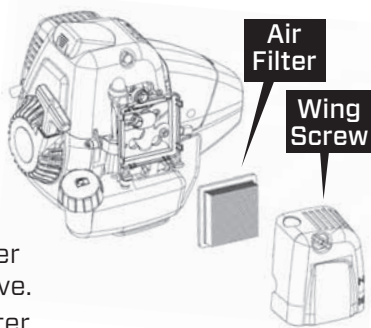

Simply tapping the filter is the best cleaning method. Never wash or clean the air filter with high compressed air or by wetting it; never place in an oil bath or cleaning solution.

The air filter is blocked if the engine speed noticeably drops when the carburetor is correctly adjusted. Under these circumstances, the filter needs replacing (part # 20 48 154).

Low engine speed due to a blocked air filter must never be compensated by incorrect carburetor adjustments. This would cause severe engine failure.

Engine failure caused by incorrect care is excluded from warranty.

- Insert the new or cleaned fabric air filter into the casing.
- Position the air filter lid with the lower guiding pins onto the housing and push into place.
- Secure the filter cover by turning the wing screw clockwise.

SPARK PLUG

Check the spark plug annually.

- Engine must be cool.
- Press the top tab of the spark plug cover (12) down (A), push back (B) and remove.
- Disconnect the spark plug cap.
- Unscrew the spark plug and dry electrodes.

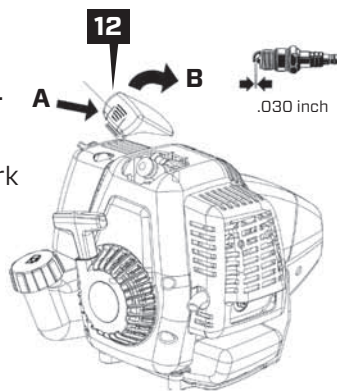

The spark plug should be replaced after 50 hours of operation or if the electrodes are badly worn.

Do not turn the engine over while the spark plug has been removed or the spark plug cap has been disconnected from the ignition cable. A spark may cause a fire.

Use spark plugs with resistor (thermal value 200) under the following description:

BOSCH: WSR6F (Original plug included, gap .015 inch)
CHAMPION: RCJ-6Y or comparable (Replacement/Service plug .030 inch.)

Only use spark plugs where the contact nut has been firmly fitted. Loose connections may produce sparks, which can cause fire. Before restarting the engine, check the high-tension ignition cable for any damage to its insulation and ensure the cable is connected securely to the spark plug cap.

- Insert the spark plug into the cylinder head and tighten it.
- Push the spark plug cap firmly over the spark plug.
- Position the spark plug cover onto the housing by aligning it with the guiding pins, push down and click into place.

TRANSMISSION

Transmissions are maintenance free, they require no adding of grease or checking.

SECURING YOUR AUGER DURING TRANSPORT

With your purchase of a StrikeMaster power auger, you have acquired one of the world's best precision cutting machines. A little prevention goes a long way. Whether you transport this machine in a truck, snowmobile, ATV or sled be sure to secure it down to prevent damage.

⚠ STORAGE ⚠

Because of today's fuels STRIKEMASTER cannot guarantee results. For summer storage or any period of time exceeding four weeks, the following steps should be carried out:

WET/NORMAL STORAGE : (recommended)

- Empty fuel tank contents and dispose of properly
- Fill fuel tank to 1/4 capacity with fresh fuel, oil and stabilizer
- Start and run engine for 2-3 minutes, varying throttle input, then turn switch to the OFF position
- If possible, run engine every 30 days for 2-3 minutes.

DRY STORAGE:

- Empty fuel tank contents and dispose of properly
- Fill fuel tank to 1/4 capacity with fresh fuel, oil and stabilizer
- Start and run engine for 2-3 minutes, varying throttle input, then turn switch to the OFF position
- Empty fuel tank contents
- Restart engine and allow engine to idle until engine stalls (due to lack of fuel)

Suggested steps for general cleaning and storage:

- Spray WD-40 or apply oil onto the blades and blade screws to reduce rust and corrosion
- Clean the engine thoroughly with a clean cloth
- Place a cover over engine assembly
- Store indoors in a well-ventilated low humidity area
- Store auger with blade guard attached





Solo® Germany-The registered Solo® trademark is licensed for use in the U. S. from the German company Solo Kleinmotoren GmbH by the U.S. affiliate, Solo Incorporated.

Transmission: Transmissions are maintenance free, they require no adding of grease or checking.

⚠ LIMITED WARRANTY ⚠

The manufacturer warrants trouble-free quality and will cover the cost of replacing parts which are found to be faulty in material or workmanship within the prescribed warranty period after the date of purchase. Please note that specific warranty conditions may vary from country to country. If in doubt, ask your equipment vendor. They are responsible for warranty matters. Solo Inc. provides the initial purchaser with a 2 year engine warranty.

We hope you will understand that we cannot be liable for damage resulting from the following causes:

- Non-compliance with the operating instructions.
- Neglecting essential maintenance and repair work.
- Damage caused by incorrect carburetor adjustment.
- Wear and tear from normal use.
- Obvious overload by continuously exceeding the maximum performance limit of the product.
- Using non-authorized tools.
- Use of force, incorrect treatment, misuse and accidents.
- Damage from excessive heat due to dirt buildup around the cooling fan housing.
- Attempted adjustments and repairs by unqualified persons.
- Use of unsuitable spare parts or third party parts, if these are the cause of the defect.
- Use of unsuitable or stale fuel.
- Damage caused by using the product in the hire or rental industry.

Normal cleaning, adjustments or maintenance work fall outside the warranty provisions. A service center authorized by the manufacturer must carry out all warranty work.

SOLO Kleinmotoren GmbH
Postfach 60 01 52
71050 Sindelfingen
DEUTSCHLAND
Tel. +49 7031 301-0
Fax +49 7031 301-130
info@solo-germany.com

SOLO Kleinmotoren GmbH
PO Box 60 01 52
71050 Sindelfingen
GERMANY
Tel. +49 7031 301-0
Fax +49 7031 301-149
export@solo-germany.com

EC DECLARATION OF CONFORMITY

In accordance with EG Directives 98/37/EC, 2000/14/EC and 89/336/EEC (amended by 92/31/EEC), SOLO Kleinmotoren GmbH, Stuttgarter Strasse 41, D-71069 Sindelfingen, being solely responsible, states that the product referred to in this declaration complies with the requirements of the Machinery Directive.

Description of product: Ice Auger			
Model/Type description	137	142	154
Sound power level Guaranteed sound	112	112	112 dB(A)
Actual sound	111	111	111 dB(A)

(EN ISO 3744, EN ISO 22868)

Applied standards: EN ISO 12100, EN 11806, ISO 14865, EN ISO 14982

Conformity assessment procedures

(98/37/EG) - Appendix V

(2000/14/EG) - Appendix V

Serial number, Build year - Type plate

This declaration of conformity loses its validity, if the equipment is converted or modified without the manufacturer's consent.

Sindelfingen, 1st January 2006

SOLO Kleinmotoren GmbH Wolfgang Emmerich
Executive Director

PARTS SUBJECT TO WEAR AND TEAR

Various parts are subject to application-specific or normal wear and must be replaced when required. The following parts are subject to normal wear and are not covered by the manufacturer's warranty:

- Air filter
- Fuel filter
- All rubber parts which come into contact with fuel
- Clutch
- Spark plug
- Starter (Recoil)
- Blades

FOR USA ONLY

Emissions Control Warranty Statement

The Environmental Protection Agency and Solo are pleased to explain the emission control system on your small non-road power equipment engine. In the US new small non-road engines must be designed, built, and equipped to meet the Environmental Protection Agency's standards. Solo must warrant the emission control system on your small non-road engine for the period of time listed below provided there has been no abuse, neglect, or improper maintenance of your small non-road engine.

Your emission control system includes parts such as the carburetor, the ignition system and the exhaust system. Where a warrantable condition exists Solo will repair your small non-road power equipment engine at no cost to you including diagnosis, parts, and labor.



First-Class
Postage
Required
Post Office
will not deliver
without proper
postage

STRIKEMASTER
10395 YELLOW CIRCLE DRIVE
MINNETONKA, MN 55343





LIMITED WARRANTY

The warrantor's obligation shall be limited to repairing or replacing any part, which upon examination by StrikeMaster, is determined to be defective. This obligation begins on the date of purchase (as evidenced by a product receipt) and continues for a period of ONE YEAR after purchase ("warranty period"), with the exception of engines and parts subject to wear and tear. This warranty is non-transferrable; warranty registration must be completed online or via USPS within 30 days of purchase to validate warranty. The warranty does not apply if product has been negligently used, misused, altered, damaged in an accident or if periodic maintenance has not been performed. Customer is responsible for shipping and transportation charges to the nearest warranty repair center.

Company warrants that Product, other than engines and parts subject to wear and tear, will perform substantially in accordance with the accompanying written materials [owner's manual] for a period of ONE YEAR. In the case of engines and parts subject to wear and tear, please refer to the chart below. Parts subject to normal wear and tear are not covered by warranty including: air filter, fuel filter, any rubber part that comes in contact with fuel, clutch, spark plug, starter (recoil), 12 volt batteries and blades. In the event applicable law imposes any implied warranties, the implied warranty period is limited to ONE YEAR from the date reflected on the product receipt. Some jurisdictions do not allow such limitations on the duration of an implied warranty, so the above limitation may not apply.

TO THE MAXIMUM EXTENT PERMITTED BY APPLICABLE LAW, THE COMPANY AND AUTHORIZED SERVICE CENTERS DISCLAIM ALL OTHER WARRANTIES, EITHER EXPRESS OR IMPLIED, INCLUDING, BUT NOT LIMITED TO IMPLIED WARRANTIES OF MERCHANTABILITY AND FITNESS FOR A PARTICULAR PURPOSE WITH REGARD TO THE PRODUCT AND WRITTEN MATERIALS [OWNER'S MANUAL]. THIS LIMITED WARRANTY GIVES CUSTOMER SPECIFIC LEGAL RIGHTS. CUSTOMER MAY HAVE OTHER RIGHTS DEPENDING ON THE JURISDICTION.

TO THE MAXIMUM EXTENT PERMITTED BY APPLICABLE LAW, IN NO EVENT SHALL THE COMPANY OR AUTHORIZED SERVICE CENTER BE LIABLE FOR ANY DAMAGES WHATSOEVER (INCLUDING WITHOUT LIMITATION, SPECIAL, INCIDENTAL, OR CONSEQUENTIAL OR INDIRECT DAMAGES FOR PERSONAL INJURY, LOSS OF BUSINESS PROFITS, BUSINESS INTERRUPTION, LOSS OF BUSINESS INFORMATION OR ANY OTHER PECUNIARY LOSS) ARISING OUT OF THE USE OF OR INABILITY TO USE THIS PRODUCT, EVEN IF THE COMPANY HAS BEEN ADVISED OF THE POSSIBILITY OF SUCH DAMAGES. IN ANY CASE, THE COMPANY'S AND AUTHORIZED REPAIR CENTER'S ENTIRE LIABILITY UNDER ANY PROVISION OF THIS AGREEMENT SHALL BE LIMITED TO THE AMOUNT ACTUALLY PAID BY YOU FOR THE PRODUCT. BECAUSE SOME JURISDICTIONS DO NOT ALLOW THE EXCLUSION OR LIMITATION OF LIABILITY FOR CONSEQUENTIAL OR INCIDENTAL DAMAGES, THE ABOVE LIMITATION MAY NOT APPLY TO YOU.

Continued satisfying performance from your StrikeMaster power ice auger may be assured by applying a minimum amount of preventive maintenance.

Limited Warranty coverage (with receipt/proof of registration)	30-Day Warranty	90-Day Warranty	1-Year Warranty	2-Year Warranty	3-Year Warranty
Wear & tear parts	X				
12-Volt Battery		X			
StrikeMaster parts			X		
Solo engine				X	
Honda engine				X	
Lithium Lazer motor					X
Lithium Lazer battery			X		

Visit our website for up to date warranty service centers.
www.strikemaster.com



WARRANTY REGISTRATION

This registration card must be returned to StrikeMaster or register online at www.strikemaster.com to validate the Limited Warranty.

DATE PURCHASED

NAME

ADDRESS

CITY STATE ZIP

For power augers, see StrikeMaster Owner's Manual for instructions on locating the model serial number.

SERIAL NUMBER _____ ENGINE/MODEL TYPE _____

PRODUCT PURCHASED	DRILL SIZE	PRODUCT PURCHASED	DRILL SIZE
<input type="checkbox"/> Lithium Lazer™	_____	<input type="checkbox"/> Lazer Pro™	_____
<input type="checkbox"/> MORA® Hand Auger	_____	<input type="checkbox"/> Lazer Mag™	_____
<input type="checkbox"/> Lazer™ Hand Auger	_____	<input type="checkbox"/> Chipper Mag	_____
<input type="checkbox"/> Honda™ 35cc Lite	_____	<input type="checkbox"/> Electra Lazer™	_____
		<input type="checkbox"/> Chipper Lite	_____